



## ekey® TOCA Solutions

### 1 Introduction

The ekey® fingerprint access system is designed for controlling:

- access through doors equipped with electrical strikes or magnetic locks;
- operation of alarm security systems configured with momentary key-switch;
- garage or gate door operated by an electrical opener;
- any device that is operated by an on/off switch;
- or, any transition base application that requires user authentication or identification

ekey® fingerprint access system replaces the need for carrying keys, cards, fobs, or even the need for memorizing codes or passwords. ekey's unique technology integration solution relieves owners, and users as well, from the frustrations of memorizing numerous codes, the inconvenient of carrying keys, or any other token...as all can be replaced by one own finger.

In a typical installation, using the ekey system entail enrolling one, two, or three fingers depending on the ekey system type being used and the access rights and authorization level given to each user as shown in the following example :





1. *First Finger* of each user - controls a Door Electric Strike
2. *Second Finger* of each user - controls arming/disarming the security System
3. *Third Finger* of each user - controls arming/disarming the security System but with duress silent alarm to the monitoring service.

The ekey® TOCA can be integrated with various applications and systems such as smart home control, engineering control system, time & attendance, etc. the integration is possible through two different options:



- **Basic Relay Monitoring** – where the 3<sup>rd</sup> party application or system monitors the ekey relay for momentary status change between open/close. The 3<sup>rd</sup> party uses this event of status change to initiate the appropriate sequence of commands and logic.
- **Advance Software integration** – where the 3<sup>rd</sup> party application or system retrieves or receives users' activity and logging information through different means (text file, ODBC, or UDP) depending on the type of ekey system being used.

## 2 A Brief Description of the Product

ekey fingerprint access system is called TOCA and it consists mainly of two basic required components plus additional optional pieces depending on the specific models



 <p>STANDARD SCANNER (Surface Mount)</p>	 <p>INTEGRA SCANNER (Flush Mount)</p>	<p>A fingerprint scanner (as an outside unit) for generating and matching key code templates that represents the fingerprints captured by the thermal line sensor scanner. The scanner is surface mount for walls or flush mount recessed into the door.</p>
 <p>CONTROL UNIT</p>		<p>A control unit (as an inside unit) that hosts and control set of normal open / normal close dry contacts (Form C switch)</p>
		<p>Additional components and accessories that varies based on the specific product or option needed.</p>

Operating and using ekey® fingerprint access system is a two step process as follows:

-  The first step, is *enrolment* (a one time procedure for each finger), which involves swiping a finger over the ekey scanner to extract and store a binary code template (No image is stored) that represents the fingerprint's unique biometric features. This and other stored codes for other fingerprints represents the authorized users whom the system can recognize to grant them access upon swiping their finger during the second step.
-  The second step is *identification*, which involves a user swiping his/her finger over the outside fingerprint scanner to extract a binary code template (No image is stored) and matching it against the previously stored code templates. If a match is found, access is granted by closing/opening the designated relay that in turn activates the connected electrical device such as a an electrical strike for a door, a zone for an alarm system, or opener for garage or gate.



The ekey® TOCA product line consists of two families:

-  **ekey® TOCAhome** – is a standalone keyless entry system that consists of one weather resistant fingerprint scanner and one control unit providing 1-to-many matching for up to 99 fingers. The system comes in three different configurations: a) 1 relay; b) 3 relays; c) 3 relays with optional computer program for added functionality.
-  **ekey® TOCAnet** – is a networkable keyless system that consists of one or more biometric access systems networked together and controlled by client/server computer program. It provides centralized management, administration, and access rules definition for any group of users.

Subject to optical and technical changes without notice; No liability assumed for setting and printing errors.

### 3 TOCA Solution Options & Description

With ekey® TOCA product line you could secure access to any location through three different options depending on the level of control required, importance of each requirement, computer/network intensity and availability, and last but not least investment budget.

ekey® TOCA solution consists of the three options as explained next.



1. **Option 1 – ekey® TOCAhome:** is the simple standalone keyless entry system with no audit trail (comes with 1 or 3 relays).
2. **Option 2 – ekey® TOCAhome pc:** is the simple standalone keyless system that provides audit trail while connected to a separate computer through a USB interface.
3. **Option 3 – ekey® TOCAnet M:** is the advanced keyless networkable entry system that allows higher level of control and management.

### 3.1 Option 1 - ekey® TOCAhome



TOCAhome is the basic and simple standalone solution that consists of one weather resistant fingerprint scanner and one control unit providing 1-to-many matching for up to 99 fingers. The system comes in two different configurations 1 relay and 3 relays. The TOCAhome with 3 relays can have only one scanner controlling all 3 relays. This is accomplished by assigning different finger for each relay. For example, index finger for relay 1, middle finger for relays 2, ring finger for relay 3. So you can deploy TOCAhome 3 system to control a door with the index finger, alarm system with the ring finger, and duress silent alarm with the middle finger!





Each TOCAhome is completely standalone and separate from any other TOCAhome system. Each user need to be enrolled separately on each system by swiping his/her finger on each scanner to be enrolled and granted access to the related door. Owner adds or deletes a user using a built-in 4 button keypad; there is no need for a computer or a technician for the operation or programming of the system.

This option consists of the following items:

QTY	Description	Picture
Only 1 per system	<p><b>Fingerprint Scanner – (used for enrollment &amp; authentication)</b></p> <ul style="list-style-type: none"> <li>■ Is an outside unit that has dual purpose: a) user enrollment; b) user authentication</li> <li>■ It should be installed in a location that is visible and easy accessible to users.</li> <li>■ The unit is spray-waterproof, and as such the mounting location should provide adequate protection against heavy rain, snow showers, and intense sunshine exposure.</li> <li>■ To ensure proper operation of the fingerprint Scanner, it should be installed at the proper height from the ground to the upper edge of the Scanner (53" for standard scanner; 62" for inetgra scanner).</li> <li>■ The fingerprint scanner is connected to the control unit by 4 conductors (2 data and 2 power). Data and power conductors should not be run in the same cable. Please refer to the wiring diagram for more info.</li> <li>■ Scanner is available in black that is actually anthracite color. Also, white color Scanner is available as special order only.</li> </ul>	 <p>The image shows two models of fingerprint scanners. The top one is a 'STANDARD SCANNER' which is a surface-mount unit with a black, weather-resistant housing and a visible sensor window. The bottom one is an 'INTEGRA SCANNER' which is a flush-mount unit, appearing as a flat, rectangular device with a recessed sensor area.</p>
Only 1 per system	<p><b>Control Unit - (used for relay control and programming)</b></p> <ul style="list-style-type: none"> <li>■ Is an inside unit that has dual purpose: a) system programming; b) relay control</li> <li>■ It should be installed away in a separate and controlled location to prevent tampering.</li> <li>■ The control unit can be order with 1 or 3 contact closures each through normal open/close relay</li> <li>■ The control unit provides contact closures with normal open/close relay. it can be ordered with either 1 or 3 relays as follows:</li> <li>■ For system with 3 relays option:</li> </ul>	 <p>The image shows a white, rectangular control unit with a small black keypad on the top surface. It is labeled 'CONTROL UNIT One or Three Relays'.</p>

Subject to optical and technical changes without notice; No liability assumed for setting and printing errors.

	<ul style="list-style-type: none"> <li>▪ Each relay is controlled by different finger that is assigned during the enrollment process of the finger.</li> <li>▪ A single Scanner control all relays...Only one scanner can be connected to the control unit.</li> </ul> <p>  Each relay can be connected to any electrical device or lock such as door strike, magnetic lock, garage door, etc. <i>(note: these are acquired separately and not supplied by ekey® TOCA system)</i> </p>	 <p>control unit with different housing</p>
--	-------------------------------------------------------------------------------------------------------------------------------------------------------------------------------------------------------------------------------------------------------------------------------------------------------------------------------------------------------------------------------------------------------------------------------------------------------------------------------------------------------------------------------------------------------------------------	--------------------------------------------------------------------------------------------------------------------------------

<p>Only 1 per system</p>	<p><b>Power Supply -</b></p> <ul style="list-style-type: none"> <li> The system is shipped with a 9 VAC power supply</li> <li> Power is applied to the Control Unit (inside unit).</li> <li> Fingerprint Scanner (outside unit) is powered by the control Unit (inside unit) using 2 conductors cable. Data and power conductors should not be run in the same cable. Please refer to the wiring diagram for more info.</li> <li> If battery operation is desired, the system can operate on regulated 12 VDC. Such 12 VDC is to be supplied separately.</li> </ul>	 <p><b>9 volt AC</b></p>
--------------------------	---------------------------------------------------------------------------------------------------------------------------------------------------------------------------------------------------------------------------------------------------------------------------------------------------------------------------------------------------------------------------------------------------------------------------------------------------------------------------------------------------------------------------------------------------------------------------------------------------------------------------------------------------------------------------------------------------------------------------------------------------------------------------------------------------------------------------------------------------------------------------------------------------------	-------------------------------------------------------------------------------------------------------------

Sample Wiring diagram for TOCAhome, TOCAhome 3, and TOCAhome pc

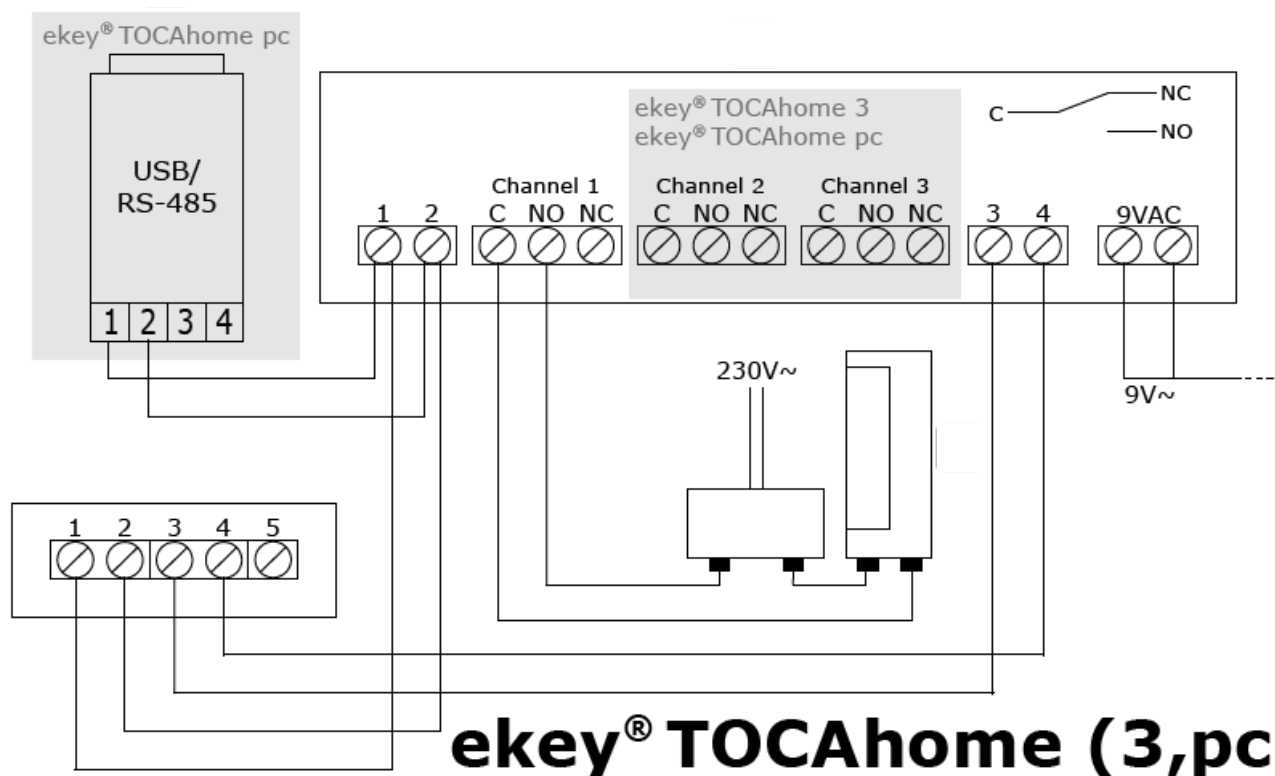

Subject to optical and technical changes without notice; No liability assumed for setting and printing errors.

### 3.1.1 TOCAhome Integration

The ekey® TOCAhome (3, pc, integra) can be integrated with various applications and systems such as smart home control, engineering control system, time & attendance, etc. the integration is possible through two different options:

**Basic Relay Monitoring** – where the 3<sup>rd</sup> party application or system monitors the ekey relay for momentary status change from/to open/close. The 3<sup>rd</sup> party uses the event of status change to initiate the appropriate sequence of commands and logic.

**Advance Software integration** – where a UDP converter that is connected to a TOCAhome system generates an information (userID, fingerID, name, relay, etc) every time a finger is swiped over the scanner as shown in the sample sniff screen print out below.

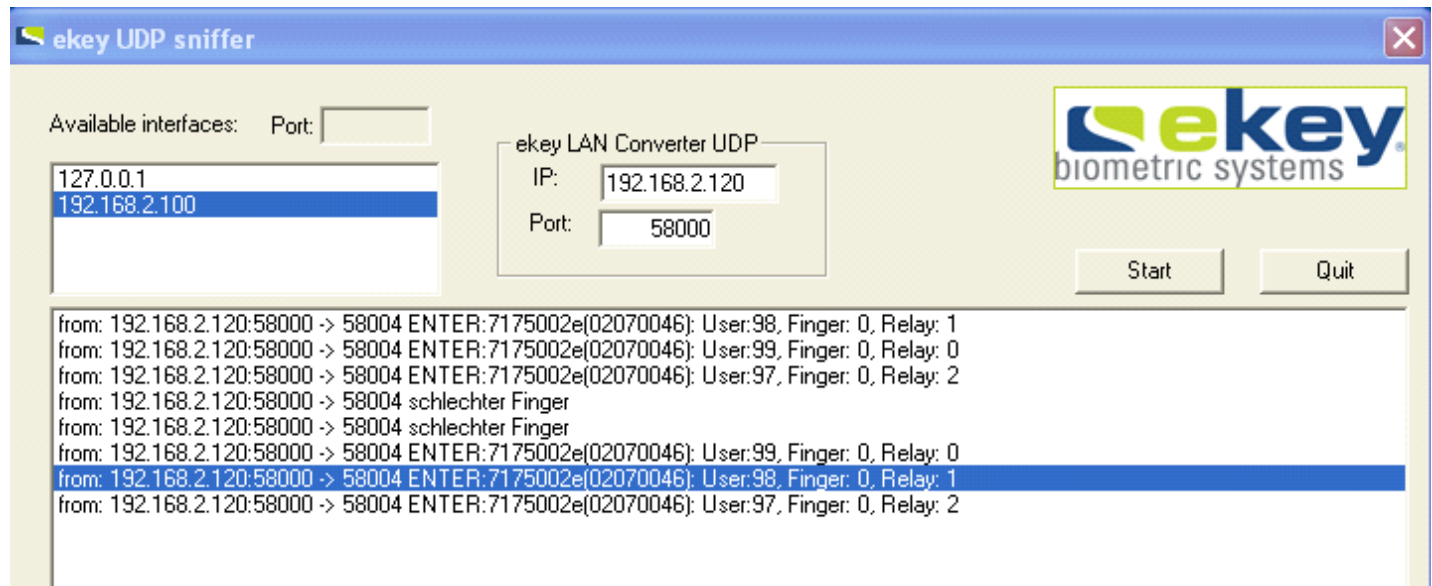

in case of authentication, the UDP converter sends information using UDP protocol with the following packet structure:

```
typedef struct {
    unsigned long nAddr; // address of module addr = (((yy*53+ww)<<16) + ssss) | 0x70000000
                        // serialno of module:800xxxwwyyssss
    unsigned char nType; // 0 -> no enter, 2 -> enter
    unsigned char nUserID; // userid from ekey TOCAhome pc
    unsigned char nFinger; // fingerid from ekey TOCAhome pc
    unsigned char nRelay; // relay from ekey TOCAhome pc
    unsigned int sName; // Name of user in unicode
} EKEYUDP, *PEKEYUDP;
```

### 3.2 Part Numbers for Ordering TOCAhome

ekey TOCAhome is suitable for the basic standalone application where scheduling, logs, and centralized management are not needed or desired. Each user need to be enrolled on each TOCAhome system. Once a user is enrolled in TOCAhome he/she has access 24/7 with no restrictions.

To order any of TOCAhome (1, 3, pc) systems, you need to decide mainly on the scanner type (surface or recess mount), number of relays (1 or 3), and color (black or white) as shown in the following table.

MODEL	SCANNER TYPE	PART NUMBER		DESCRIPTION
		BLACK	WHITE	
TOCAhome	Standard Scanner (Surface Mount)	130001	130194	ekey® TOCAhome (1 Relay)
		130002	130195	ekey® TOCAhome 3 (3 Relay)
		130154	130198	ekey® TOCAhome pc
	Integra Scanner (Flush Mount)	130411	-	ekey® TOCAhome integra (1 Relay)
		130412	-	ekey® TOCAhome 3 integra (3 Relay)
		130413	-	ekey® TOCAhome pc integra
	Additional Components	100460		ekey® Converter UDP



Subject to optical and technical changes without notice; No liability assumed for setting and printing errors.

### 3.3 Option 2 - ekey® TOCAhome pc

TOCAhome pc has the same function and features as the basic TOCAhome; however this system provides the following additional functionality through a computer program:



- Assign name to users
- Assign names to each of the three relays
- adjusting relay open time in increments of seconds up to 244 sec
- designate one of the three relays to activate when scanner fails to authenticate a user's fingerprint
- detail audit trail while connected to the computer and limited activity list while not connected to the computer

This option consists of the following items:

QTY	Description	Picture
Only 1 per system	<p><b>Fingerprint Scanner – (used for enrollment &amp; authentication)</b></p> <ul style="list-style-type: none"> <li>■ Is an outside unit that has dual purpose: a) user enrollment; b) user authentication</li> <li>■ Is an outside unit that should be installed in a location that is visible and easy accessible by users.</li> <li>■ The unit is spray-waterproof, and as such the mounting location should provide adequate protection against heavy rain, snow showers, and intense sunshine exposure.</li> <li>■ To ensure proper operation of the fingerprint Scanner, it should be installed at the proper height from the ground to the upper edge of the Scanner (53" for standard scanner; 62" for inetgra scanner).</li> <li>■ The fingerprint scanner is connected to the control unit by 4 conductors (2 data and 2 power). Data and power conductors should not be run in the same cable. Please refer to the wiring diagram for more info.</li> <li>■ Scanner is available in black that is actually anthracite color. Also, white color Scanner is available as special order only.</li> </ul>	 <p>STANDARD SCANNER (surface mount)</p> <p>INTEGRA SCANNER (flush mount)</p>
Only 1 per system	<p><b>Control Unit - (used for rely control &amp; basic programming)</b></p> <ul style="list-style-type: none"> <li>■ Is an inside unit that has dual purpose: a) relay control; b) basic system programming (in addition to the computer program)</li> <li>■ Is an inside unit that is installed away in a separate location preventing tampering.</li> <li>■ The control unit provides 3 contact closures each through normal open/close relay.</li> <li>■ Each of the three relays is           <ul style="list-style-type: none"> <li>▪ Controlled by different finger that is assigned during the enrollment process.</li> <li>▪ Possible to name and adjust opening time.</li> <li>▪ A single Scanner controls all relays...Only one scanner can</li> </ul> </li> </ul>	 <p>CONTROL UNIT</p> <p>control unit with different housing</p>

Subject to optical and technical changes without notice; No liability assumed for setting and printing errors.

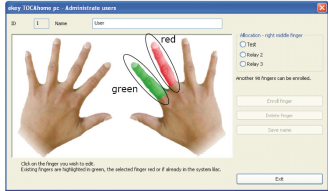

	<p>be connected to the control unit.</p> <ul style="list-style-type: none"> <li>Each relay can be connected to any electrical device or lock such as door strike, magnetic lock, garage door, etc. (<i>note: these are acquired separately and not supplied by ekey® TOCA system</i>)</li> </ul>	
<p>Only 1 per system</p>	<p><b>Power Supply –</b></p> <ul style="list-style-type: none"> <li>The system is shipped with a 9 VAC power supply</li> <li>Power is applied to the Control Unit (inside unit).</li> <li>Fingerprint Scanner (outside unit) is powered by the control Unit (inside unit) using 2 conductors cable. Data and power conductors should not be run in the same cable. Please refer to the wiring diagram for more info.</li> <li>If battery operation is desired, the system can operate on regulated 12 VDC. Such 12 VDC is to be supplied separately.</li> </ul>	
<p>Only 1 per system</p>	<p><b>USB/RS-485 Cable and Converter –</b></p> <ul style="list-style-type: none"> <li>For interfacing control unit with the computer using USB/RS-485 converter.</li> <li>On the computer side the connection is USB cable.</li> <li>On the Control Unit side the connection is RS-485.</li> <li>Refer to previous TOCAhome, TOCAhome 3, and TOCAhome pc sample Wiring diagram.</li> </ul>	
<p>Only 1 per system</p>	<p><b>Administration Interface program –</b></p> <ul style="list-style-type: none"> <li>A window based user interface that allows user addition, deletion, and audit trail reporting.</li> <li>The computer program can be used for assigning users names, selecting fingers to enroll, defining relay names, adjusting relay open time and generate audit trail while connected to a computer through a USB/RS-485 interface.</li> <li>The format of the audit trail is generated by the system and written to CSV file depends on the control unit connection status with the computer as shown in the Sample Audit Trail below: <ul style="list-style-type: none"> <li>If the control unit is online, then date, time, user, and access details are reported.</li> <li>If the control unit is offline, then limited info is reported which consist of user number, enrolled finger number, action status.</li> </ul> </li> </ul>	

Subject to optical and technical changes without notice; No liability assumed for setting and printing errors.

<b>TOCAhome pc Sample Audit Trail in CSV File</b>	
<b>On-line</b>	<b>Offline</b>
97;unbekannt ;F01;COM4;10/16/2005 1:57:17 PM;O0	01;F01;not matched
02;Hassan;F07;com4crt;10/16/2005 2:13:10 PM;O1	01;F01;not matched
02;Hassan;F06;com4crt;10/16/2005 2:13:39 PM;O0	06;F07;enrolled
98;unbekannt ;F01;COM6;10/18/2005 10:26:28 AM;O1	06;F07;matched
04;Georg;F07;COM6;10/18/2005 10:27:33 AM;O0	05;F01;matched
98;unbekannt ;F01;COM6;10/18/2005 10:28:53 AM;O1	95;F07;not matched
09;Dean;F08;COM7;10/20/2005 12:41:15 PM;O0	04;F01;matched
11;gg;F08;COM6;10/28/2005 4:29:12 PM;O0	03;F01;matched
06;t;F01;COM6;10/28/2005 4:32:10 PM;O0	02;F01;not matched
95;Donna;F04;COM6;11/9/2005 12:13:07 PM;O1	01;F01;matched
95;Donna;F04;COM6;11/9/2005 12:13:35 PM;O1	02;F01;enrolled
95;Donna;F04;COM6;11/9/2005 12:13:41 PM;O1	02;F01;matched
95;Donna;F08;COM6;11/9/2005 12:16:04 PM;O2	01;F01;matched
94;Hassa;F07;COM6;11/9/2005 6:46:16 PM;O1	01;F01;not matched
94;Hassa;F08;COM6;11/9/2005 6:46:23 PM;O2	95;F08;not matched
01;Rory;F07;COM6;11/9/2005 6:47:20 PM;O1	01;F01;not matched
94;Hassa;F06;COM6;11/15/2005 11:15:56 AM;O0	94;F08;not matched
01;John;F03;COM6;11/15/2005 11:18:12 AM;O1	02;F01;not matched
94;Hassa;F07;COM6;11/30/2005 12:01:07 PM;O1	93;F01;not matched
94;Hassa;F07;COM6;11/30/2005 12:01:52 PM;O1	94;F07;matched
07;Luis;F06;COM6;11/30/2005 12:04:16 PM;O1	95;F07;not matched

### 3.3.1 Part Numbers for Ordering TOCAhome PC

Please refer to 3.1.1 Part Numbers for Ordering TOCAhome

### 3.4 Option 3 - ekey® TOCAnet M

ekey® TOCAnet is the networkable version of the system that consists of multiple sets each with weather resistant fingerprint scanner/s (outside unit) and one control unit (inside unit) providing 1-to-many matching for up to 200 fingers at each scanner. Inside and outside units are connected on RS485 serial bus to LAN/RS485 converter. The converter is connected to the LAN using RJ45 plug. The system architecture is client/server that allows any local/remote computer on the LAN/WAN to access it and managed it based on a defined security level.

A user has to swipe his/her finger on a USB Scanner connected to computer for enrolled. The generated fingerprint template is stored at central server and then distributed to each Scanner in the network based on access rights.

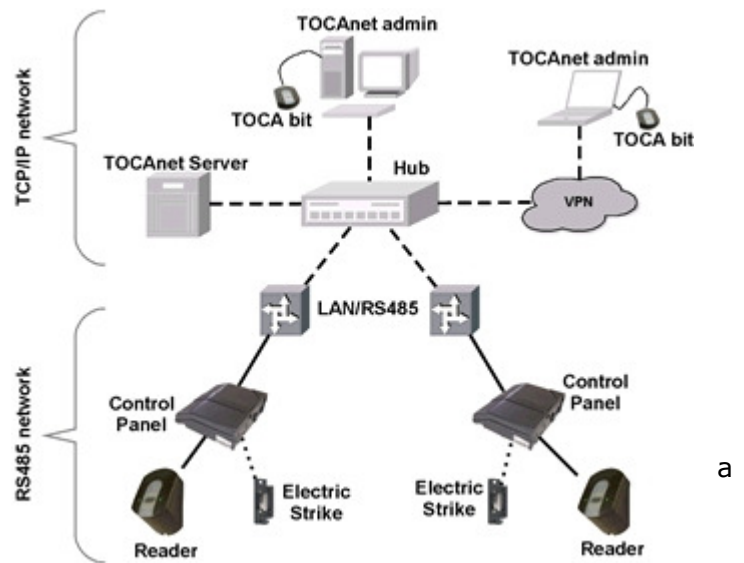



In addition to the ekey basic special features, the network version TOCAnet, offers features such as

- **Door Man or Secretary Mode** - an icon in the Windows taskbar (system tray) allows activation of any relay (to open a door for example) right from the computer.
- **Single/Dual Authorization** - each system can be configured to activate its relays with single finger, two fingers of the same person, or two fingers from two different users (for high security applications).
- **Misuse prevention** - After 10 consecutive unauthorized swipes the system blocks itself for 40 seconds, indicated by a red/orange blinking LED.
- **Time Schedule** - restrict users' access time to a specific time period and during a specific day of the week and for a specific system by the simple drag and drop
- **Remote Access** - through a LAN or VPN or WAN network, remote access and management of the system is possible for adding/deleting/changing users, terminal, or system configuration
- **Centralized Management** - Users and terminals are managed by a client program that includes activities such as:
  - adding/deleting, activating/deactivating users or terminals
  - Fingerprints are captured through USB fingerprint scanner and distributed to each scanner or group of scanners in the system depending on assigned access rights
- **Logging** - Activity logs are reported in real-time while scanner is online with the server; otherwise it is captured and maintained locally at each scanner until communication is restored

This option consists of the following items:

Subject to optical and technical changes without notice; No liability assumed for setting and printing errors.

QTY	Description	Picture
1 per control unit	<p><b>Fingerprint Scanner - (used for authentication only)</b></p> <ul style="list-style-type: none"> <li>■ Is an outside unit that should be installed in a location that is visible and easy accessible to users.</li> <li>■ The unit is spray-waterproof, and as such the mounting location should provide adequate protection against heavy rain, snow showers, and intense sunshine exposure.</li> <li>■ To ensure proper operation of the fingerprint Scanner, it should be installed at the proper height from the ground to the upper edge of the Scanner (53" for standard scanner; 62" for inetgra scanner).</li> <li>■ The fingerprint scanner is connected to the control unit by 4 conductors (2 data and 2 power). Data and power conductors should not be run in the same cable. Please refer to the wiring diagram for more info.</li> <li>■ Scanner is available in black that is actually anthracite color. Also, white color Scanner is available as special order only.</li> </ul>	 <p>STANDARD SCANNER (surface mount)</p> <p>INTEGRA SCANNER (flush mount)</p>
1 per system... more systems can be added as needed	<p><b>Control Unit – (used for relay control)</b></p> <ul style="list-style-type: none"> <li>■ Is an inside unit that is installed away in a separate location preventing tampering.</li> <li>■ The control unit provides 3 contact closures each through normal open/close relay.</li> <li>■ Each of the three relays is <ul style="list-style-type: none"> <li>▪ Controlled by different finger that is assigned during the enrollment process. This allows a single scanner to control all relays.</li> <li>▪ Possible to name and adjust opening time.</li> <li>▪ If needed and depending on the application specifics, each relay can be controlled by and have separate scanner provided the user is aware of which finger needs to swipe on which scanner.</li> </ul> </li> <li>■ Each relay can be connected to any electrical device or lock such as door strike, magnetic lock, garage door, etc. <i>(note: these are acquired separately and not supplied by ekey® TOCA system)</i></li> </ul>	 <p>CONTROL UNIT</p> <p>control unit with different housing</p>
1 per system	<p><b>Power Supply –</b></p> <ul style="list-style-type: none"> <li>■ The system is shipped with a 9 VAC power supply</li> <li>■ Power is applied to the Control Unit (inside unit).</li> <li>■ Fingerprint Scanner (outside unit) is powered by the control Unit (inside unit) using 2 conductors cable. Data and power conductors should not be run in the same cable. Please refer to the wiring diagram for more info.</li> <li>■ If battery operation is desired, the system can operate on regulated 12 VDC. Such 12 VDC is to be supplied separately.</li> </ul>	

Subject to optical and technical changes without notice; No liability assumed for setting and printing errors.

QTY	Description	Picture
1 per 4 systems	<p><b>ekey LAN/RS485 converter –</b></p> <ul style="list-style-type: none"> <li>■ The ekey converter function as a serial device manager and a translator between two sides: TCP/IP and RS-485 as explained next.</li> <li>■ On LAN side – <ul style="list-style-type: none"> <li>▪ Each converter on the network should be assigned unique static IP address to manage up to 4 sets (1 set = 2 devices... 1 scanner + 1 control unit) per single static IP.</li> <li>▪ Each converter is connected to the network over the LAN using RJ-45 plug where the TOCANet server application is running on a server with another static IP.</li> <li>▪ You can add multiple converters per system, each will have its own static IP address</li> </ul> </li> <li>■ On RS485 – <ul style="list-style-type: none"> <li>▪ The converter has one port that supports RS-485 for communicating with the fingerprint scanners and control units.</li> <li>▪ Each ekey converter supports 4 sets (1 set = 2 devices... 1 scanner + 1 control unit).</li> <li>▪ The internal and external unit must be connected by two cables as follows: <ul style="list-style-type: none"> <li>○ <i>Data Cable or Bus Connection:</i> clamp 1 and clamp 2 of each control unit and fingerprint scanner on the same bus are daisy chain connected in sequence to the corresponding clamps on ekey converter RS-485 port using CAT 5/6 or bell wire with minimum wire cross section of 0.22 mm<sup>2</sup>. The bus is terminated by 120 ohm resistor. When multiple sets are daisy-chained together, it is highly recommended to use control and scanner units interchangeably for ease troubleshooting and faultless operation in case the wiring is broken.</li> <li>○ <i>Power Cable and connection:</i> each fingerprint scanner is powered by its correspondent control unit using a two conducts with minimum wire cross section of 0.75 mm<sup>2</sup>. ekey converter is powered by any single device.</li> </ul> </li> </ul> </li> </ul>	

Subject to optical and technical changes without notice; No liability assumed for setting and printing errors.

Sample wiring diagram of the converter and system over the RS-485 bus

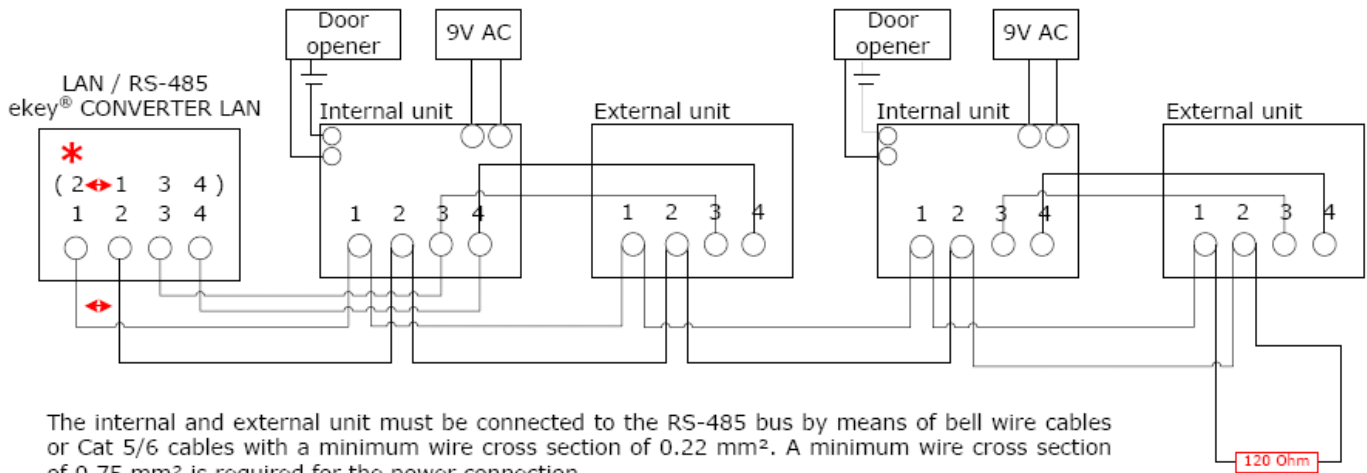

<p>1 or more as needed</p>	<p><b>USB fingerprint scanner – (used for enrollment)</b></p> <ul style="list-style-type: none"> <li>The USB fingerprint scanner will be used by the system administrator to enroll users' fingerprints in the system.</li> <li>One fingerprint scanner to be enough for the system. Additional Scanner/s will be required if remote user enrolment is desired</li> </ul>	
<p>One license multiple copies per installation</p>	<p><b>TOCANet Server &amp; Administration Program –</b></p> <ul style="list-style-type: none"> <li>A window based services and user interface.</li> <li>The services are installed on a server on the LAN that allows remote login over VPN or WAN if remote access is required.</li> <li>The user interface allows user addition, fingerprint enrollment, access right definition, etc.</li> <li>Audit trails are generated and stored at each scanner. Once it is online with the server, audit log data are reported in various options (text file or ODBC) as defined by the administrator as shown in the sample below.</li> </ul> <pre>UserID;UserName;Finger;TerminalID;Terminal;Time;Relay;ECode;EText -1;;-1;0;EHX Demo System;12/21/2005 4:03:13 PM;-1;134;Update -1;;-1;36;Demo 1;12/21/2005 4:03:13 PM;-1;134;Connected -1;;-1;36;Demo 1;11/30/1999 12:03:11 AM;-1;134; 11;Hares, Hassan;8;36;Demo 1;12/21/2005 4:03:15 PM;3;136;Enter 11;Hares, Hassan;6;36;Demo 1;12/21/2005 4:03:17 PM;1;136;Enter 0;unknown;-1;36;Demo 1;12/21/2005 4:03:20 PM;-1;147;Refused 11;Hares, Hassan;7;36;Demo 1;12/21/2005 4:03:22 PM;2;136;Enter</pre>	

Subject to optical and technical changes without notice; No liability assumed for setting and printing errors.

### 3.5 Part Numbers for Ordering TOCAnet

ekey TOCAnet is suitable when advance application is desired to manage one or more doors all networkable together and controlled by centralized management system that provides access to each specific user or group of users through each specific door or group of doors, and during certain time schedule for certain day of the week.

To order TOCAnet, you need to decide mainly on the following:

- a) *Installation status (new or existing)*: for each new installation you will need to order a startup kit that includes all required HW & SW to control one door to the LAN using a unique static IP.
- b) *The number of doors to be controlled*: for each door controlled by ekey you will need to order one set i.e. one scanner and one control
- c) *The wiring scheme implemented (homerun or daisy chain)*:
  - a. for homerun wiring scheme a set with unique IP should be ordered;
  - b. for daisy chain scheme a basic set with sharing IP should be order (max 4 sets can be daisy chain)
- d) *The scanner type (surface or recess mount)*:
  - a. Surface mount scanner is the Standard Scanner
  - b. Flush or Recess mount scanner is the integra Scanner
- e) *The scanner color (black or white)*

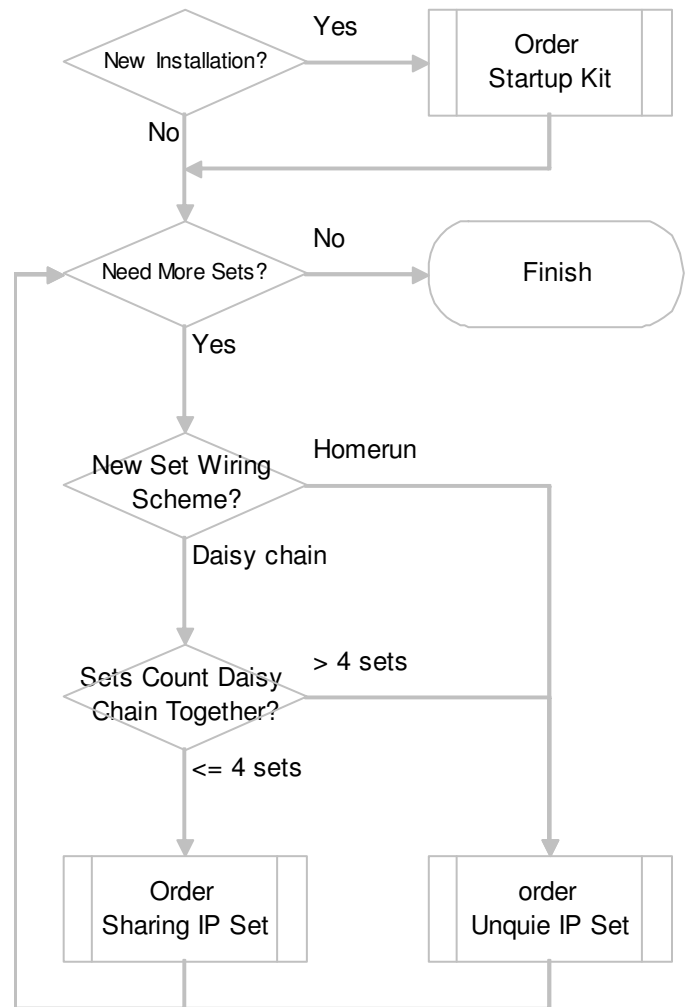

The following table lists the exact part numbers to be used for ordering TOCAnet as explained earlier.

MODEL	SCANNER TYPE	PART NUMBER		DESCRIPTION
		BLACK	WHITE	
TOCAnet	STANDARD SCANNER (Surface Mount)	130270	130271	ekey® TOCAnet M ( <b>Sharing IP set</b> )
		130440	130439	ekey® TOCAnet M ( <b>Unique IP set</b> )
		130450	130449	ekey® TOCAnet M ( <b>Startup Kit</b> )
		130320	130321	ekey® TOCAnet M (Scanner only)
	INTEGRA SCANNER (Flush Mount)	130414	-	ekey® TOCAnet M integra ( <b>Sharing IP Set</b> )
		130420	-	ekey® TOCAnet M integra ( <b>Unique IP Set</b> )
		130421	-	ekey® TOCAnet M integra ( <b>Startup Kit</b> )
		130422	-	ekey® TOCAnet M integra (Scanner only)
	Required Components	100013		ekey Bit (USB Fingerprint enrollment scanner)
		100340		ekey Converter (LAN/RS485) + TOCAnet SW

Subject to optical and technical changes without notice; No liability assumed for setting and printing errors.



## 4 TOCA Accessories

Various face plates and covers are available for the TOCA standard surface mount fingerprint scanner as shown below. Some of these items have lead time of 3-4 weeks.

### 4.1 In-wall mounting set - Stainless Steel

The in-wall mounting set (Part number 100307) is made from stainless steel. It is used for recessing the surface mount fingerprint scanner. Installing this set requires preparing an opening in the wall a little over 7"x6"x3".



### 4.2 Round Cover – Gold

The round cover (Part number 100272) is gold coated. It is used to give the surface mount fingerprint scanner different look. This cover is not secured by any screw and it is installed by aligning and snapping it over the surface mount fingerprint scanner. It can be removed by pushing on the scanner while pulling the bottom edge away from the wall.



### 4.3 Round Cover – Stainless Steel

The round cover (Part number 100231) is made from stainless steel. It is used to give the surface mount fingerprint scanner different look. This cover is not secured by any screw and it is installed by aligning and snapping it over the surface mount fingerprint scanner. It can be removed by pushing on the scanner while pulling the bottom edge away from the wall.



### 4.4 Weather Protection – Stainless Steel

The Weather Protection (Part number 100306) is made from stainless steel. It is used to give the surface mount fingerprint scanner extra protection against rain, snow, and sunlight when the fingerprint scanner is directly exposed to the environment condition. This cover is secured to the wall behind the scanner by 4 screws.



### 4.5 Secure Round Cover – Stainless Steel

The secure round cover (Part number 100308) is made from stainless steel. It is used to give the surface mount fingerprint scanner different look. This cover is secured by a plate affixed by screws to the wall behind the scanner, and a hidden screw that extends internal by pushing the bottom edge of the round cover away from the scanner.



## 4.6 Fingerprint Scanner with LED for Status Indication

The fingerprint scanner can be fitted with a ring or cover that includes three different colored LEDs (yellow, green, & red). These LEDs can be used to give the end-user visual indication that reflects the status of the system that is being controlled by ekey. In a typical installation, these LEDs can be used to indicate to the end-user whether the alarm security system is *not-secured*, *ready-to-arm*, or *armed* as explained in the following example.

- **Yellow light** – when the yellow light is turned ON, it indicates that the security system is not ready to be armed. This means one or more motion sensor, door contact, or any defined zone in the security system is not secured. The idea here is to indicate to the end-user that while the yellow light is on the security system will not arm even if he/she swiped his/her designed finger for arming the security system.
- **Green Light** – when the green light is turned ON, it indicates that the security system is ready to be armed. Meaning all motion detectors, door contacts, and zones are secured. The idea here is to indicate to the end-user that while the green light is on the security system will arm if he/she swiped his/her designed finger for arming the security system.
- **Red Light** – when the red light is turned ON, it indicates that the security system is armed. The idea here is to indicate to the end-user that while the red light is on the security system will disarm if he/she swiped his/her designed finger for arming the security system.

The LEDs are standard 12volts colored lights (yellow, green, & red) positioned around the ekey fingerprint scanner but they are not powered or controlled by the ekey system; however, these light shows the status of a system integrated with ekey. The LEDs It comes in two options black plastic (Part number 100426) stainless steel (part number 100428). Both options are not secured by any screws are installed by aligning and snapping it over the fingerprint scanner. They can be removed by pushing on the scanner while pulling the bottom edge away from the wall.

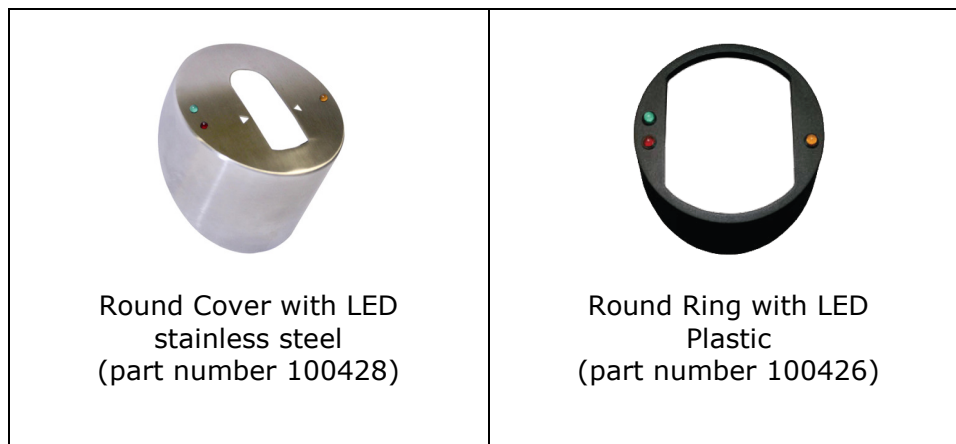

Subject to optical and technical changes without notice; No liability assumed for setting and printing errors.